

# FIRST OPERATION OF THE FLASH MACHINE PROTECTION SYSTEM WITH LONG BUNCH TRAINS

L. Fröhlich\*, University of Hamburg and DESY, Hamburg, Germany  
A. Hamdi, M. Luong, J. Novo, CEA-Saclay, Gif-sur-Yvette, France  
M. Görler, P. Göttlicher, D. Nölle, D. Pugachov, H. Schlarb, S. Schreiber,  
M. Staack, M. Werner, DESY, Hamburg, Germany

## Abstract

The linac-based free electron laser facility FLASH<sup>1</sup> at DESY Hamburg is designed to transport an electron beam with an average power of more than 50 kW. To avoid serious damage to accelerator components, a fast active machine protection system (MPS) stops the production of new bunches if hazardous machine conditions are detected. This paper gives an overview of the MPS topology and its subsystems. Furthermore, we present results from the commissioning of the fast beam interlock system that has for the first time allowed to operate the accelerator with macropulses of up to 600 bunches.

## INTRODUCTION

The FLASH linac currently employs 40 superconducting 9-cell cavities distributed over five cryogenic modules to accelerate an electron beam to an energy of up to 700 MeV. The beam is guided through an undulator of approximately 30 m length to initiate a free electron laser (FEL) process based on the SASE principle. The facility is now alternating between blocks of accelerator development and user operation, supplying experimenters with pulsed radiation of high brilliance in the XUV wavelength range between 13 and 50 nm. [1]

As typical for superconducting linacs, the transported bunches are grouped in macropulses or bunch trains. The viable rf pulse length limits the length of a bunch train to 800  $\mu$ s. With the standard bunch frequency of 1 MHz and a macropulse repetition rate of 5 Hz, the power delivered to the beam dump amounts to  $\sim$ 3 kW. If the future option for high duty cycle operation with 9 MHz/10 Hz is realized, this figure increases above 50 kW. Even on partial loss of the beam along the linac, the induced heat load and radiation can cause substantial damage to accelerator components. Therefore, an active protection system is required to ensure safe operation of the machine.

## MPS ORGANIZATION

The machine protection system of the FLASH linac is a substantially enhanced version of the system used in phase 1 of the TESLA Test Facility [2]. Since the descrip-

\* lars.froehlich@desy.de

<sup>1</sup>Since April 2006, FLASH—Free Electron Laser in Hamburg—is the new name for the VUV-FEL, part of the TESLA Test Facility TTF.

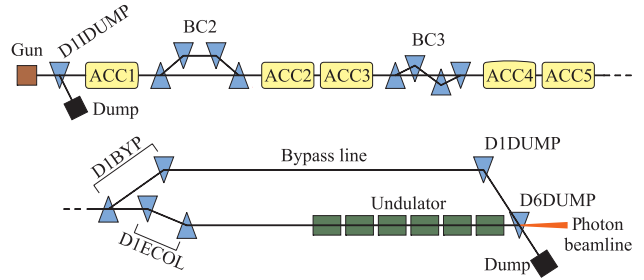

Figure 1: Schematic of the FLASH linac. The depicted elements include the five acceleration modules  $ACC_n$ , the two bunch compressors  $BC_n$ , and the main dipole magnets.

tion of the basic design in [3], the operational experience gained during the commissioning of FLASH has led to a number of changes that will be discussed in the following.

## Loss detection

The detection of beam and darkcurrent losses in the linac is based on two independent approaches. The FPGA-controlled *Toroid Protection System* [4] measures the transmission by comparing the readings from charge monitors (toroids) in the injector and dump part of the machine, and generates alarms within less than 110 ns if one of several configurable thresholds is exceeded.

The second pillar of beam loss detection is constituted by a set of 51 photomultipliers and 18 secondary emission multipliers distributed along the machine. These *beam loss monitors* (BLMs) provide a bunch-resolved online display of electromagnetic shower intensities (Fig. 2). VME-based alarm generators with a reaction time far below 1  $\mu$ s check whether user-defined thresholds for one or multiple bunches, or for the integrated signal are exceeded. They also generate an alarm on failure of the high voltage supply, or if a misconfiguration has been detected.

As the permanent magnets of the undulator are susceptible to radiation, close monitoring of beam losses is required to avoid degradation of the field quality. Therefore, the undulator section features the highest concentration of BLMs in the whole machine, with 26 monitors currently in place and another 12 to be installed until the end of the year.

## Response to alarms

The purpose of any MPS is to detect situations which may lead to damage of components, and to take appro-

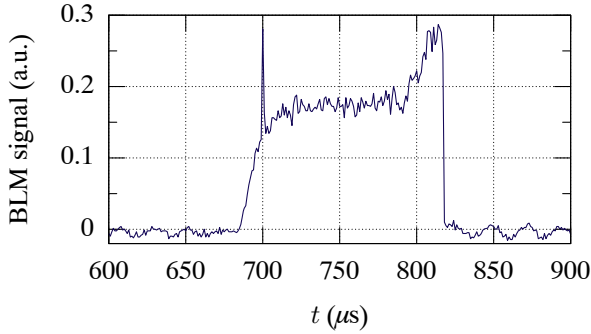

Figure 2: Signal from a beam loss monitor behind the collimation section. At  $t = 700 \mu\text{s}$ , a part of one single bunch is lost. The losses visible from 690–820  $\mu\text{s}$  are caused by darkcurrent from the gun.

appropriate counter-measures. These potentially harmful conditions can be classified into three main categories:

**Fast** Since the loss of a complete macropulse may already present a substantial hazard, a fast system must stop the production of bunches within the train, i.e. on a time scale of few  $\mu\text{s}$ .

**Intermediate** For the major part of potential dangers, a reaction between two macropulses is sufficient. Since the time constants of all magnets employed at FLASH are of the order of tens of milliseconds or more, the failure of power supplies falls into this category.

**Slow** Even if moderate losses of darkcurrent or of few bunches do not pose an immediate threat, they contribute to the deposited radiation dose, and may thus cause damage over time scales of minutes or days. This issue is of special importance for the undulator.

To guarantee an appropriate response to events on any of these timescales, the FLASH MPS uses two independent subsystems: A network of *Beam Interlock Concentrators* for fast events, and a programmable logic control—the *Beam Interlock System*—for intermediate and slow events.

### Beam Interlock Concentrators (BICs)

The function of a BIC module can be described as a fast logical OR concentrating 16 alarm inputs to two outputs within a processing time of  $\sim 50 \text{ ns}$ , with a configurable mask that allows to suppress any of the input channels. Ten modules are currently in use, connected in a tree-like fashion as illustrated in Fig. 3. The biggest part of the input channels is used by the 69 BLM alarm signals, but also the TPS, the cavity quench detection, and a fast vacuum shutter are connected. When any of the inputs show an alarm, the top-level BICs will switch off the injector laser to suppress the production of new bunches in the gun, and cut the first acceleration module off from rf power as a precaution against further transport of darkcurrent.

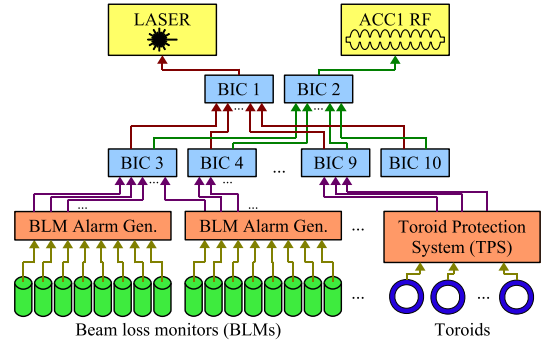

Figure 3: Organization of *beam interlock concentrators*. BIC 3–10 collect alarms from various alarm generators and relay them to BIC 1–2, which switch off the photoinjector laser and the rf power of the first acceleration module.

Measurements have confirmed that the reaction time of the BIC system to beam losses is below  $4 \mu\text{s}$ . This time is dominated by cable delays, and it means that up to three more bunches enter the machine after detection of the loss at the standard bunch frequency of 1 MHz.

### Beam Interlock System (BIS)

While the BIC system has been designed to guarantee minimum response time to fast events, the emphasis for the *Beam Interlock System* has been placed on flexibility. The programmable logic control continuously monitors the status of critical components like magnet power supplies, screens, collimators, and valves. It also checks the flow of cooling water, and the compliance to temperature limits.

From the status of the main dipole magnets and of several valves, the BIS deduces an *operation mode* defining the basic beam path through the machine according to Tab. 1. As a simple protective measure, no beam is allowed if there is no valid operation mode.

Furthermore, the BIS selects one of three *beam modes* as shown in Tab. 2. Besides defining the maximum allowed number of bunches per macropulse, the beam mode also determines whether the fast protection via the BIC system is active. This policy allows the operation under charge loss as long as only few bunches per macropulse are needed, which is necessary for tuning and for experiments using the beam. While the operator can choose between short and long mode, the BIS will automatically reduce to short or single mode if obstacles like screens are moved into the beam path, or if other conditions are met.

Apart from these general safety features, attempts have been made to limit the radiation dose deposited in the undulator with a special BIS routine. Due to the dense placement of BLMs in the undulator section, there is considerable overlap in their geometrical acceptances, and electromagnetic showers are usually observed on more than one monitor. The *BIS-BLM protection* takes advantage of this by counting the number of simultaneous BLM alarms in

Table 1: List of *operation modes* with the required valve and dipole magnet settings, and the maximum allowed beam mode.

<i>operation mode</i>	<i>conditions</i>	<i>beam mode</i>
Gun	gun valve open, ACC1 valve closed, D1IDUMP off	short
Analysis	gun valve open, ACC1 valve closed, D1IDUMP on	long
Bypass	all valves open, D1BYP on, D1DUMP on, D6DUMP off	long
FEL	all valves open, D1BYP off, D1ECOL on, D6DUMP on	long

Table 2: List of *beam modes* with the maximum allowed number of bunches per macropulse.

<i>beam mode</i>	<i>nr. of bunches</i>	<i>BIC system</i>
Single	2	disabled
Short	30	disabled
Long	no limit	active

the section. If 2 alarms are pending over 120 s, 4 over 30 s, or 8 over 5 s, the beam is stopped and has to be restarted manually via the control system. To allow tuning, the tolerances of this routine can be increased for 30 minutes.

Figure 4 shows the average dose rates in the first two undulator segments measured with thermoluminescence dosimeters [5]. Since the activation of the BIS-BLM protection in September 2005, the dose rates have been predominantly below 10 Gy/day, indicating that—together with an overall improved understanding of orbit and optics—the requirement of avoiding beam stops has led to a reduction of losses.

## OPERATION WITH LONG MACROPULSES

The commissioning of MPS components relevant for long pulse operation has been completed in August 2006. The increase of the gun rf pulse length from 70 to 800  $\mu$ s led to the expected rise of darkcurrent losses in the bunch compressors and in the collimation section by about an order of magnitude. By successive optimization of orbit and optics, the beam losses could be reduced to a minimum, and operation of the FEL with 600 bunches per macropulse was possible with minimal interference of the BIC system. At an average energy of 20  $\mu$ J per photon pulse, the output power during the test run has reached about 60 mW.

Imperfections of the rf regulation constitute the main problem in setting up a stable transmission of long macropulses. Due to poorly compensated beam loading or transient behavior at the beginning of the rf pulse, the bunches at the head of the macropulse can experience amplitudes and phases of the accelerating field that deviate significantly from the designated values. For the first bunch, an

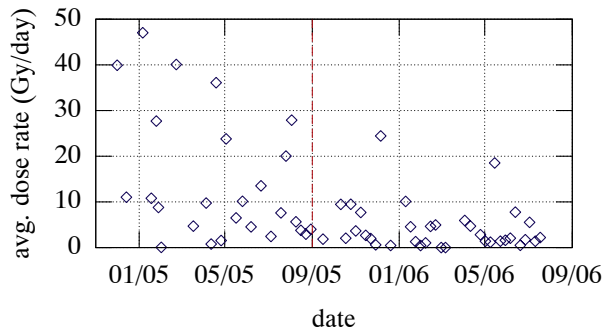

Figure 4: Average dose rates measured in the first two undulator segments.

energy deviation of 0.6 % with respect to the last bunches of a 300  $\mu$ s long macropulse has been measured after the first acceleration module. This effectively enlarges the total phase space occupied by the macropulse and thus reduces the tolerance for jitter and drifts.

## CONCLUSION AND OUTLOOK

The FLASH machine protection system reliably prevents damage of the accelerator due to beam losses, with the total downtime of the linac caused by MPS failures and misconfigurations amounting to only few hours. It is also successful in limiting the slow accumulation of radiation dose in the undulator.

While the number of bunches per macropulse has been limited to 30 during past accelerator runs, the recent commissioning of the beam interlock concentrator system with reaction times in the microsecond range now allows to operate the machine with bunch trains of up to 800 pulses. We expect that future user experiments will benefit highly from the improved duty cycle.

## ACKNOWLEDGEMENTS

We wish to thank all members of the operation crew for their outstanding commitment and support. The assistance of the controls and low-level rf groups is greatly appreciated.

## REFERENCES

- [1] V. Ayvazyan, et al., “First operation of a free-electron laser generating GW power radiation at 32 nm wavelength”. *Eur. Phys. J. D*, 37:297–303, November 2006.
- [2] H. Schlarb, et al., “Expansion of the fast linac protection system for high duty cycle operation at the TESLA Test Facility”. *EPAC’02*, pp. 1966–1968. Paris, France, June 2002.
- [3] D. Nölle, et al., “The beam inhibit system for TTF II”. *DI-PAC’03*, pp. 62–64. Mainz, Germany, 2003.
- [4] A. Hamdi, et al., “VHDL design and simulation of a fast beam loss interlock for TTF2”. *EPAC’04*, pp. 2020–2022. Lucerne, Switzerland, 2004.
- [5] T. Vielitz, Hasylab, Hamburg, private communication.